

8.8 Rozměry

8.8 Dimensions

8.8 Abmessungen

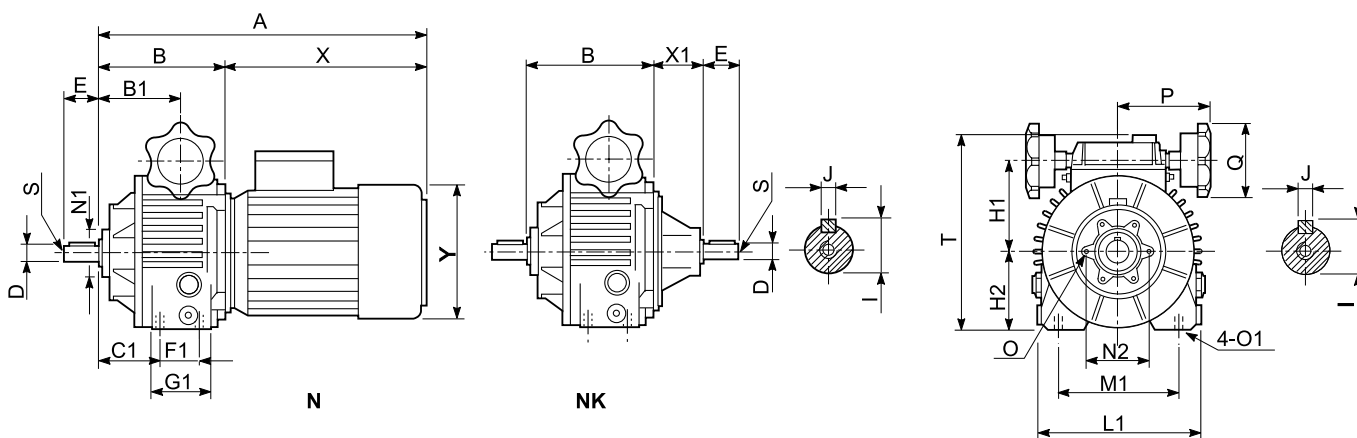

| Typ Type Typ | A | B | B1 | C1 | D | E | F1 | G1 | H1 | H2 | I | J | L1 | M1 | N1 | N2 | O | O1 | P | Q | S | T | X | X1 | Y | Kg |
|--------------------|-----|-----|-----|----|----|----|----|----|-----|-----|------|---|-----|-----|----|-----|----|-----|-----|----|----|-----|-----|----|-----|----|
| N003 | 302 | 110 | 66 | 44 | 11 | 23 | 36 | 55 | 79 | 58 | 12.5 | 4 | 128 | 100 | 42 | 56 | M6 | M8 | 97 | 89 | M5 | 160 | 192 | 42 | 122 | 5 |
| N005 | 336 | 118 | 78 | 61 | 14 | 30 | 36 | 55 | 88 | 73 | 16 | 5 | 153 | 120 | 56 | 75 | M6 | M8 | 97 | 89 | M6 | 185 | 218 | 50 | 137 | 7 |
| N010 | 383 | 145 | 95 | 75 | 19 | 40 | 45 | 82 | 107 | 91 | 21.5 | 6 | 187 | 140 | 56 | 75 | M6 | M10 | 107 | 89 | M6 | 222 | 239 | 65 | 158 | 13 |
| N020 | 450 | 172 | 105 | 82 | 24 | 50 | 58 | 82 | 126 | 108 | 27 | 8 | 220 | 190 | 75 | 100 | M8 | M10 | 107 | 89 | M8 | 264 | 278 | 70 | 177 | 20 |

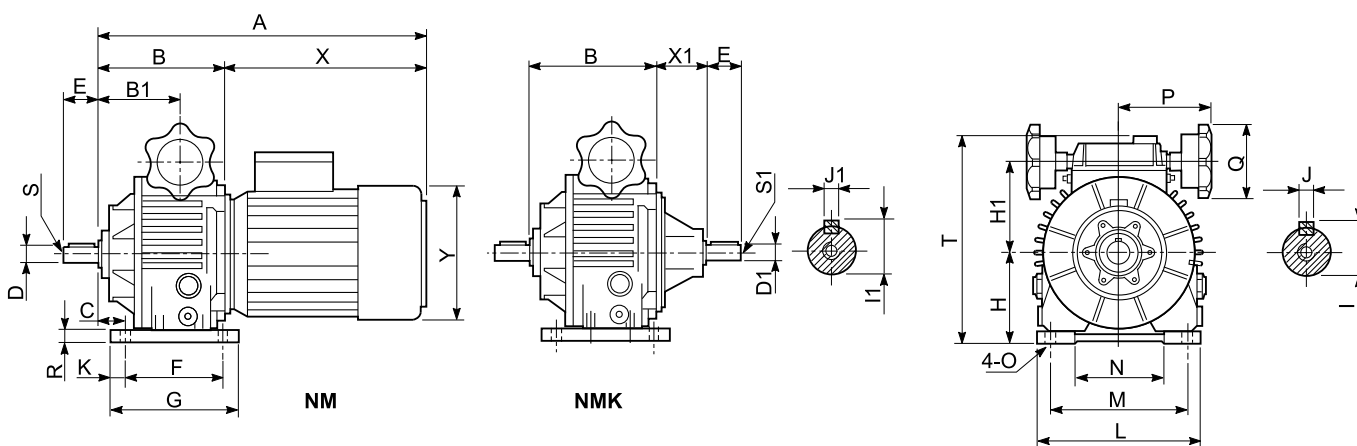

| Typ Type Typ | A | B | B1 | C | D | D1 | E | F | G | H | H1 | I | I1 | J | J1 | K | L | M | N | O | P | Q | R | S | S1 | T | X | X1 | Y | Kg |
|--------------------|-----|-----|-----|------------|----|----|------------|-----|-----|-----|-----|--------------|------|-----------|----|------|-----|-----|-----|----|-----|-----|------|--------------|-----|-----|-----|----|-----|----|
| NM003 | 302 | 110 | 66 | 25 (14) | 11 | 11 | 23 (30) | 105 | 130 | 71 | 76 | 12.5 (16) | 12.5 | 4 (5) | 4 | 12.5 | 140 | 110 | 80 | 9 | 97 | 89 | 11 | M5 (M6) | M5 | 173 | 192 | 42 | 122 | 6 |
| NM005 | 336 | 118 | 78 | 30 (19) | 14 | 14 | 30 (40) | 105 | 130 | 90 | 88 | 16 (21.5) | 16 | 5 (6) | 5 | 12.5 | 155 | 120 | 83 | 10 | 97 | 89 | 13 | M6 | M6 | 202 | 218 | 50 | 137 | 8 |
| NM010 | 382 | 143 | 95 | 35 (24) | 19 | 19 | 40 (50) | 125 | 150 | 106 | 107 | 21.5 (27) | 21.5 | 6 (8) | 6 | 12.5 | 190 | 160 | 120 | 12 | 107 | 89 | 13.5 | M6 (M8) | M6 | 242 | 239 | 65 | 158 | 14 |
| NM020 | 441 | 171 | 104 | 50 (28) | 24 | 24 | 50 (60) | 140 | 165 | 125 | 126 | 27 (31) | 27 | 8 | 8 | 12.5 | 230 | 180 | 130 | 12 | 107 | 89 | 16 | M8 (M10) | M8 | 277 | 270 | 70 | 177 | 21 |
| NM030/050 | 546 | 206 | 122 | 25 (38) | 28 | 28 | 60 (80) | 230 | 270 | 150 | 158 | 31 (41) | 31 | 8 (10) | 8 | 20 | 300 | 245 | 190 | 14 | 155 | 120 | 20 | M10 (M12) | M10 | 337 | 340 | 95 | 197 | 51 |

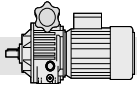

8.8 Rozměry

8.8 Dimensions

8.8 Abmessungen

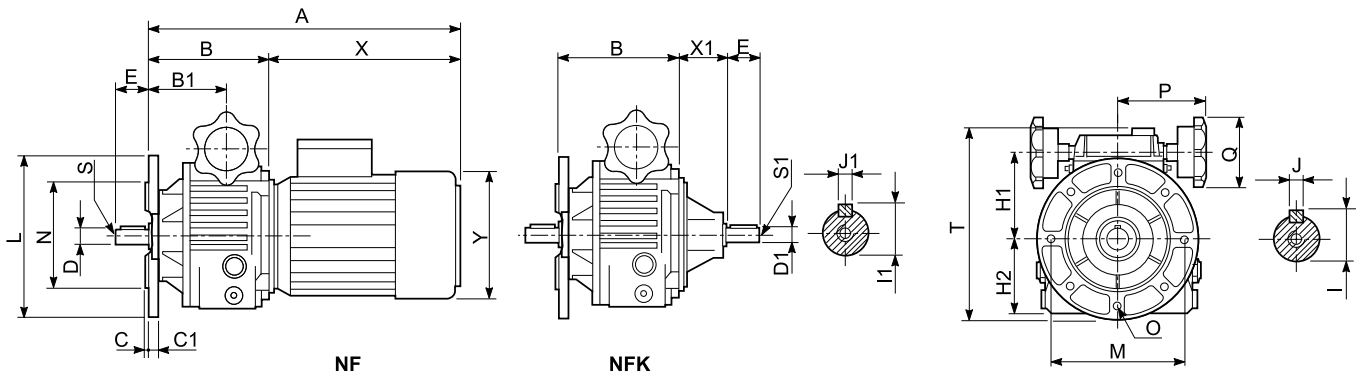

| Typ Type Typ | A | B | B1 | C | C1 | D | D1 | E | H1 | H2 | I | I1 | J | J1 | L | M | N | O | P | Q | S | S1 | T | X | X1 | Y | Kg |
|--------------------|-----|-----|-----|------|------|------------|----|------------|-----|-----|--------------|------|-----------|----|--------------|--------------|--------------|------------|-----|-----|--------------|-----|--------------|-----|----|-----|----|
| NF003 | 302 | 110 | 66 | 3.5 | 8 | 11 (14) | 11 | 23 (28) | 76 | 58 | 12.5 (16) | 12.5 | 4 (5) | 4 | 140 (160) | 115 (130) | 95 (110) | 9 (9) | 97 | 89 | M5 | M5 | 165 (175) | 192 | 42 | 122 | 6 |
| NF005 | 338 | 120 | 80 | 3.5 | 10.5 | 14 (19) | 14 | 28 (38) | 88 | 73 | 16 (21.5) | 16 | 5 (6) | 5 | 160 (200) | 130 (165) | 110 (130) | 9 (11) | 97 | 89 | M6 | M6 | 188 (208) | 218 | 50 | 137 | 8 |
| NF010 | 384 | 145 | 97 | 3.5 | 13.5 | 19 (24) | 19 | 38 (48) | 107 | 91 | 21.5 (27) | 21.5 | 6 (8) | 6 | 200 | 165 | 130 | 11 | 107 | 89 | M6 (M8) | M6 | 237 | 239 | 65 | 158 | 14 |
| NF020 | 443 | 173 | 106 | 4 | 14 | 24 (28) | 24 | 48 (58) | 126 | 108 | 27 (31) | 27 | 8 | 8 | 200 (250) | 165 (215) | 130 (180) | 11 (14) | 107 | 89 | M8 (M10) | M8 | 260 (277) | 270 | 70 | 177 | 21 |
| NF030/050 | 548 | 208 | 124 | 4(5) | 16 | 28 (38) | 28 | 58 (78) | 158 | 134 | 31 (41) | 31 | 8 (10) | 8 | 250 (300) | 215 (265) | 180 (230) | 14 | 155 | 120 | M10 (M12) | M10 | 336 | 340 | 95 | 197 | 51 |

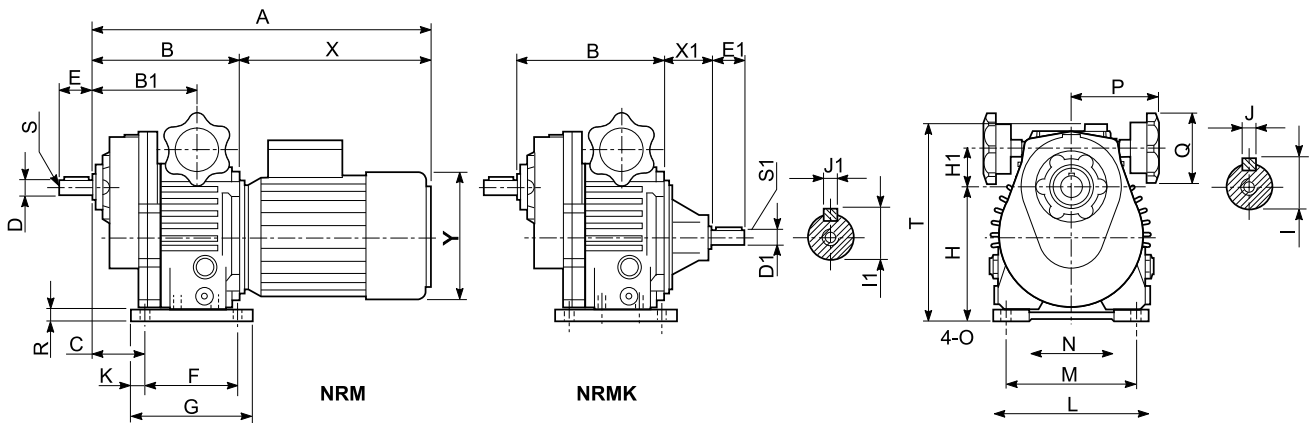

| Typ Type Typ | A | B | B1 | C | D | D1 | E | E1 | F | G | H | H1 | I | I1 | J | J1 | K | L | M | N | O | P | Q | R | S | S1 | T | X | X1 | Y | Kg |
|--------------------------|-----|-----|-----|----|------------|----|----|----|-----|-----|--------------|----|----------------|------|------------|----|------|-----|-----|-----|----|-----|-----|------|-----|----|-----|-----|----|-----|----|
| NRM003 | 331 | 139 | 108 | 57 | 19 (20) | 11 | 30 | 23 | 105 | 130 | 111 (116) | 36 | 21.5 (22.5) | 12.5 | 6 | 4 | 12.5 | 140 | 110 | 80 | 9 | 97 | 89 | 11 | M6 | M5 | 173 | 192 | 42 | 122 | 7 |
| NRM005 | 363 | 145 | 105 | 54 | 19 (20) | 14 | 30 | 30 | 105 | 130 | 140 (135) | 38 | 21.5 (22.5) | 16 | 6 | 5 | 12.5 | 155 | 120 | 83 | 10 | 97 | 89 | 13 | M6 | M6 | 202 | 218 | 50 | 137 | 11 |
| NRM010 | 418 | 179 | 131 | 69 | 24 (25) | 19 | 35 | 40 | 125 | 150 | 169 (160) | 44 | 27 (28) | 21.5 | 8 | 6 | 12.5 | 190 | 160 | 120 | 12 | 107 | 89 | 13.5 | M8 | M6 | 242 | 239 | 65 | 158 | 9 |
| NRM020 | 471 | 201 | 135 | 78 | 28 (30) | 24 | 45 | 50 | 140 | 165 | 188 (190) | 63 | 31 (33) | 27 | 8 | 8 | 12.5 | 230 | 180 | 130 | 12 | 107 | 89 | 16 | M10 | M8 | 277 | 270 | 70 | 177 | 33 |
| NRM030 NRM050 | 586 | 246 | 165 | 63 | 38 (40) | 28 | 60 | 60 | 230 | 270 | 230 (224) | 78 | 41 (43) | 31 | 10 (12) | 8 | 20 | 300 | 245 | 190 | 14 | 155 | 120 | 20 | M12 | M8 | 337 | 340 | 95 | 197 | 75 |

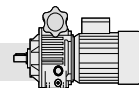

8.8 Rozměry

8.8 Dimensions

8.8 Abmessungen

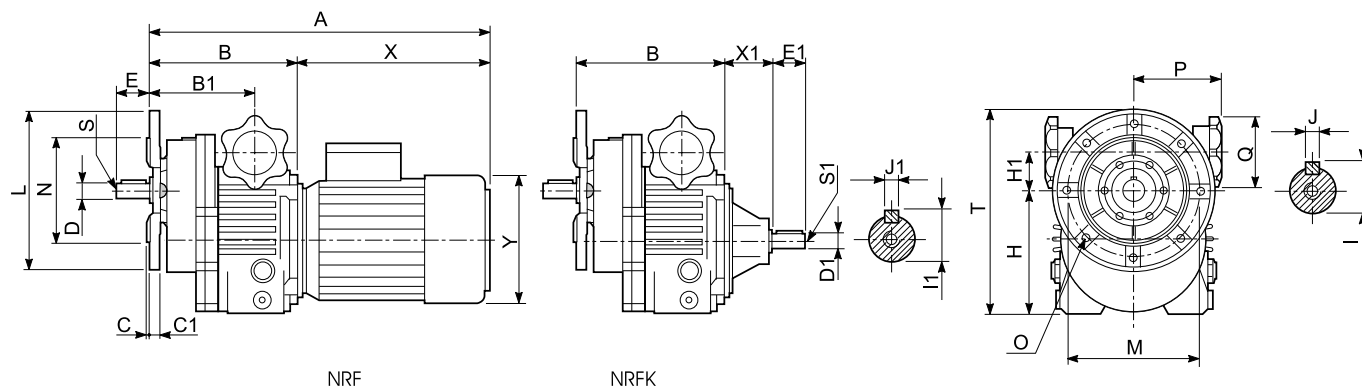

| Typ Type Typ | A | B | B1 | C | C1 | D | D1 | E | E1 | H | H1 | I | I1 | J | J1 | L | M | N | O | P | Q | S | S1 | T | X | X1 | Y | Kg |
|--------------------|-----|-----|-----|-----|------|----|----|----|----|-----|----|------|------|----|----|-----|-----|-----|----|-----|-----|-----|----|-----|-----|----|-----|----|
| NRF003 | 333 | 141 | 112 | 3.5 | 8 | 19 | 11 | 28 | 23 | 98 | 36 | 21.5 | 12.5 | 6 | 4 | 160 | 130 | 110 | 9 | 97 | 89 | M6 | M5 | 178 | 192 | 42 | 122 | 7 |
| NRF005 | 372 | 154 | 114 | 3.5 | 10.5 | 19 | 14 | 28 | 30 | 123 | 38 | 21.5 | 16 | 6 | 5 | 160 | 130 | 110 | 9 | 97 | 89 | M6 | M6 | 203 | 218 | 50 | 137 | 11 |
| NRF010 | 419 | 180 | 130 | 3.5 | 13.5 | 24 | 19 | 33 | 40 | 154 | 44 | 27 | 21.5 | 8 | 6 | 200 | 165 | 130 | 11 | 107 | 89 | M8 | M6 | 254 | 239 | 65 | 158 | 19 |
| NRF020 | 473 | 203 | 137 | 4 | 14 | 28 | 24 | 43 | 50 | 171 | 63 | 31 | 27 | 8 | 8 | 250 | 215 | 180 | 14 | 107 | 89 | M10 | M8 | 296 | 270 | 70 | 177 | 33 |
| NRF030/050 | 588 | 248 | 167 | 4 | 16 | 38 | 28 | 58 | 60 | 214 | 78 | 41 | 31 | 10 | 8 | 300 | 265 | 230 | 14 | 155 | 120 | M12 | M8 | 364 | 340 | 95 | 197 | 75 |

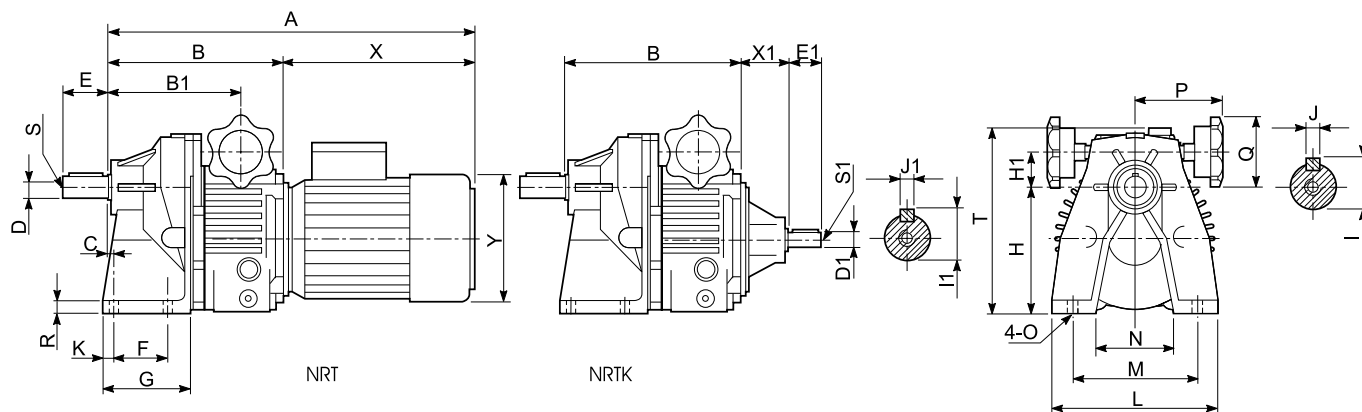

| Typ Type Typ | A | B | B1 | C | D | D1 | E | E1 | F | G | H | H1 | I | I1 | J | J1 | K | L | M | N | O | P | Q | R | S | S1 | T | X | X1 | Y | Kg |
|--------------------|-----|-----|-----|-----|----|----|-----|----|-----|-----|-----|----|------|------|----|----|----|-----|-----|-----|----|-----|-----|----|-----|----|-----|-----|----|-----|----|
| NRT003 | 376 | 184 | 140 | 20 | 19 | 11 | 40 | 23 | 45 | 80 | 110 | 36 | 21.5 | 12.5 | 6 | 4 | 14 | 130 | 105 | 70 | 9 | 97 | 89 | 10 | M6 | M5 | 167 | 192 | 42 | 122 | 9 |
| NRT005 | 412 | 194 | 154 | 6 | 24 | 14 | 50 | 30 | 70 | 110 | 130 | 38 | 27 | 16 | 8 | 5 | 15 | 180 | 150 | 90 | 11 | 97 | 89 | 12 | M8 | M6 | 192 | 218 | 50 | 137 | 13 |
| NRT010 | 456 | 218 | 171 | 7.5 | 28 | 19 | 60 | 40 | 70 | 115 | 163 | 44 | 31 | 21.5 | 8 | 6 | 14 | 215 | 165 | 100 | 11 | 107 | 89 | 15 | M8 | M6 | 231 | 239 | 65 | 158 | 21 |
| NRT020 | 551 | 281 | 215 | 25 | 38 | 24 | 70 | 50 | 85 | 142 | 195 | 46 | 41 | 27 | 10 | 8 | 23 | 250 | 185 | 130 | 14 | 107 | 120 | 16 | M10 | M8 | 266 | 270 | 70 | 177 | 33 |
| NRT030/050 | 686 | 346 | 261 | 19 | 48 | 28 | 100 | 60 | 130 | 178 | 250 | 59 | 51.5 | 31 | 14 | 8 | 17 | 310 | 240 | 160 | 17 | 155 | 120 | 18 | M10 | M8 | 337 | 340 | 95 | 197 | 75 |