

ZA..A

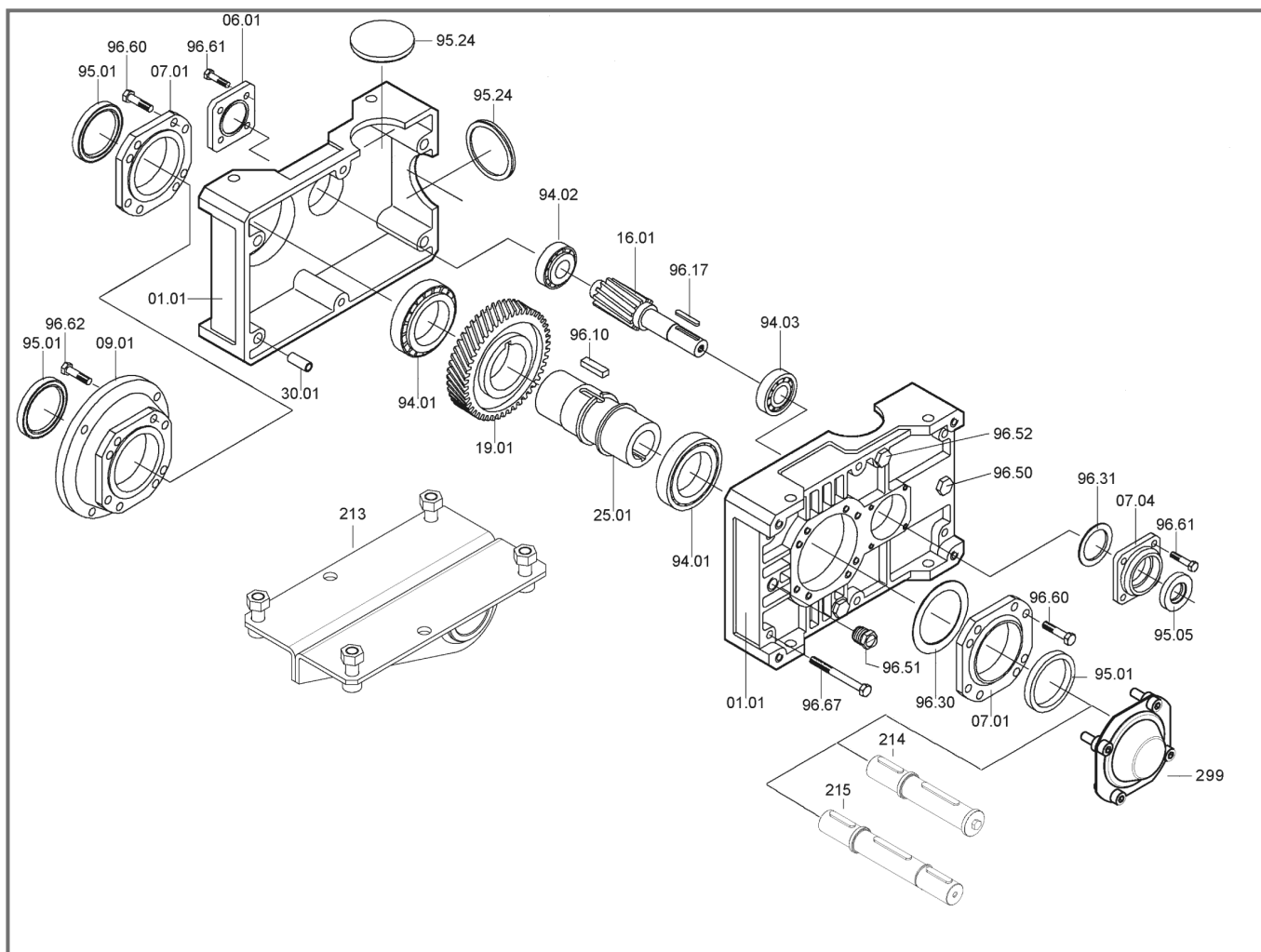

ZA	Ložiska/ Bearings / Lager			Těsnění / Oilseals / Öldichtungen	
	94.01	94.02	94.03	95.01	95.05
71A	32008 40/68/19	30302 15/42/14.25	32004 20/42/15	40/56/8	20/35/7
90A	32010 50/80/20	30204 20/47/15.25	32005 25/47/15	50/65/8	25/47/7
112A	32012 60/95/23	30305 25/62/18.25	30206 30/62/17.25	60/80/10	30/52/7
140A	32015 75/115/25	32206 30/62/21.25	32008 40/68/19	75/95/10	40/56/8
180A	32019 95/145/32	32208 40/80/24.75	32010 50/80/20	95/125/12	50/65/8
225A	32026 130/200/45	31310 50/110/29.25	33113 65/110/34	130/160/12	65/80/10

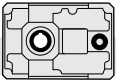

ZA..B - ZF..B

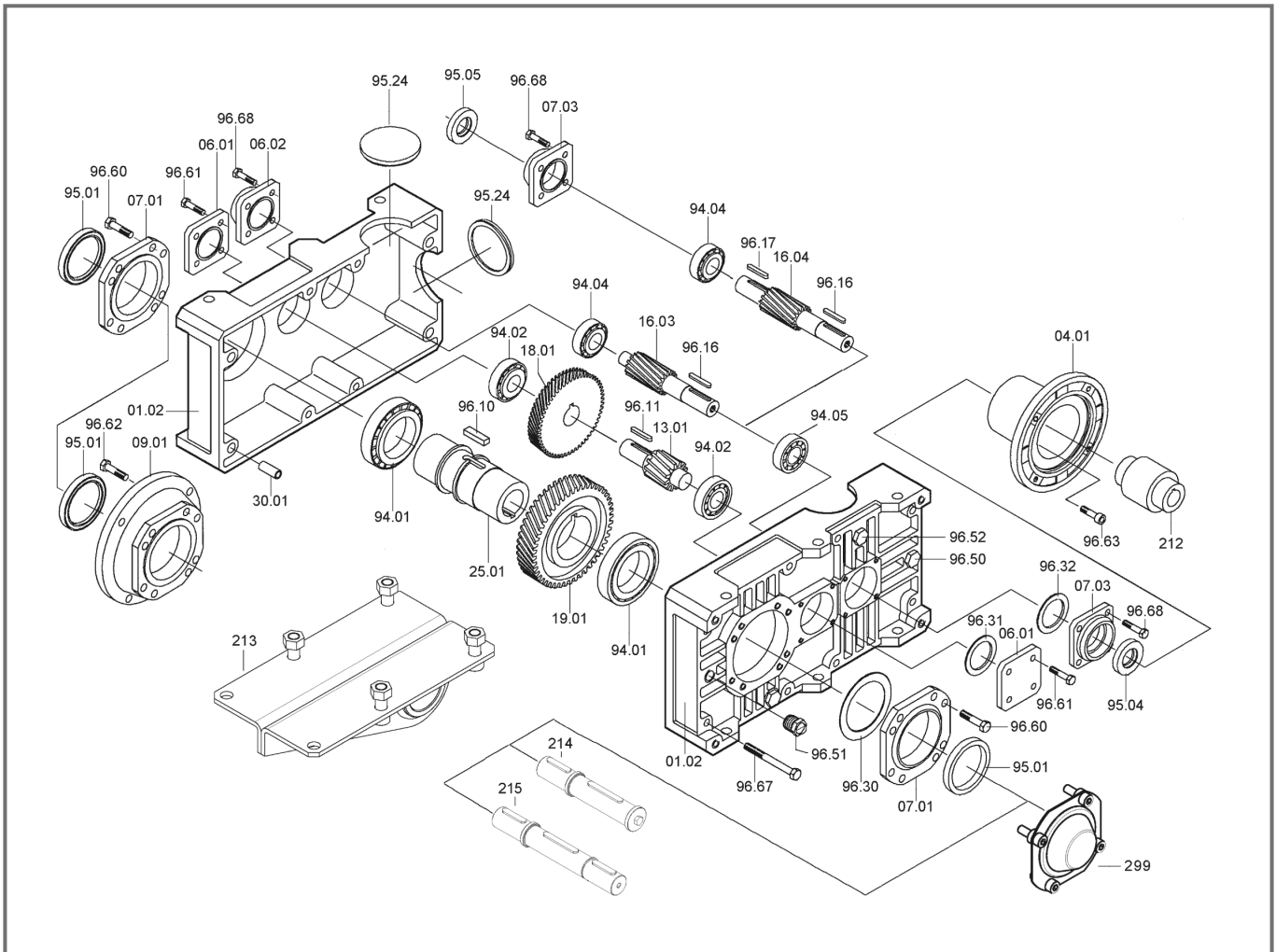

ZA - ZF	Ložiska / Bearings / Lager				Těsnění / Oilseals / Öldichtungen		
	94.01	94.02	94.04	94.05	95.01	95.04	95.05
80B	32010 50/80/20	30204 20/47/15.25	30302 15/42/14.25	32004 20/42/15	50/65/8	20/40/7	15/40/10
100B	32012 60/95/23	30305 25/62/18.25	30204 20/47/15.25	32005 25/47/15	60/80/10	25/47/7	20/47/7
125B	32015 75/115/25	32206 30/62/21.25	30305 25/62/18.25	30206 30/62/17.25	75/95/10	30/52/7	25/52/7
160B	32019 95/145/32	32207 35/72/24.25	32206 30/62/21.25	32008 40/68/19	95/125/12	40/56/8	30/56/10
180B	32024 120/180/38	31309 45/100/27.25	30307 35/80/22.75	32208 40/80/24.75	120/160/15	40/62/7	35/62/7
200B	32026 130/200/45	31310 50/110/29.25	32208 40/80/24.75	32010 50/80/20	130/160/12	50/65/8	40/65/10

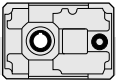

ZA..B - ZF..B - ZA..C - ZF..C

Blokace volného směru otáčení - Backstop device - Rücklaufsperr

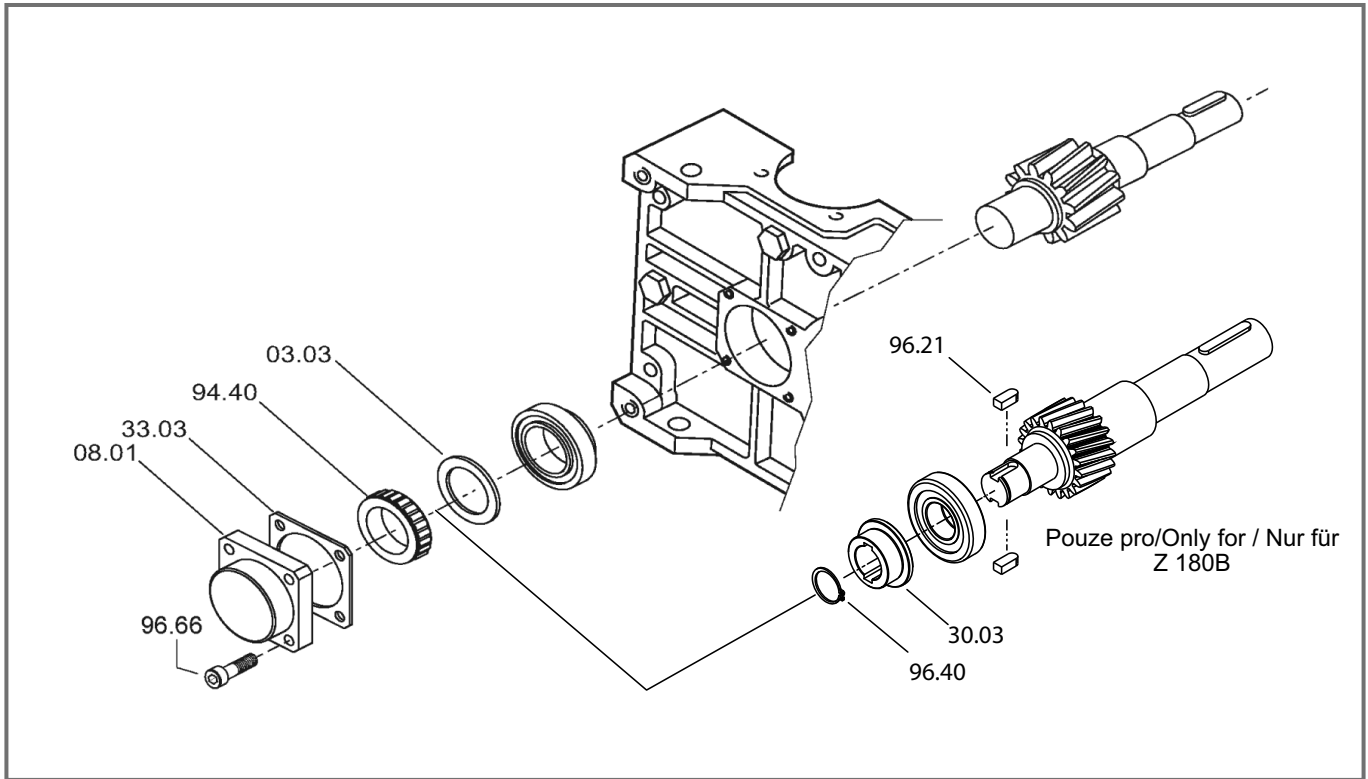

Z...B	Volnoběžné kolo / Free wheel / Freilaufgrad 94.40
80	FE 423 Z
100	FE 428 Z
125	BF 50 Z 16
160	BF 70 Z 21
180	FE 8049 Z 19
200	FE 8040 Z 19

Z...C	Volnoběžné kolo/ Free wheel / Freilaufgrad 94.40
80	FE 423 Z2
100	FE 423 Z
125	FE 428 Z
160	BF 50 Z 16
180	BF 50 Z 16
200	BF 70 Z 21

Při objednávání náhradního dílu vždy uveďte jeho číslo(viz nákresy), dále datum, kód výrobku a provedení ze štítku převodovky (viz obrázek štítku)

When ordering a spare part, the spare part number (see exploded technical drawing) , the date (1), the code number (2) and the variant number (3) should always be reported. (See plate)

Bei der Bestellung von Ersatzteilen sind Ersatzteilnummer (s. Explosionszeichnung), Datum (1), Artikelnummer (2) und Variantennummer (3) anzugeben. (s. Schild)

TYP: popis
TYPE: description
TYP: Bezeichnung

POMĚR: převodový poměr
RATIO: reduction ratio
ÜBERS.: Untersetzungsverhältnis

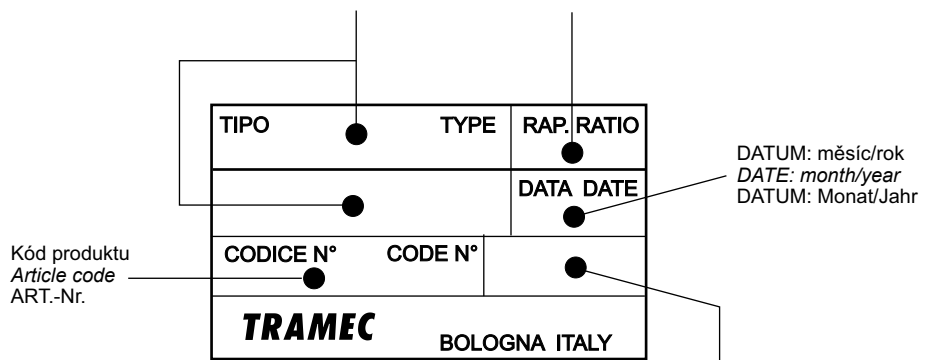

DATUM: měsíc/rok
DATE: month/year
DATUM: Monat/Jahr

VARIANTA: alfanumerický kód
VARIANT: alphanumeric code
VARIANTE: alphanumerische Nummer