

2.10 Rozměry

2.10 Dimensions

2.10 Abmessungen

	TA...- TF...				
	56B		63B		
R	73.5		75		
F	9		9		
e	45		50		
H h8	65		70		
X h8	65		80		
E h8	65		70		
M	M8 x 12		M8 x 14		
C f8	70		80		
K	85		100		
L	59		65		
S	71		85		
f	9		9		
m	45		55		
c	73.5		80		
N2	6	8	8	8	8
M2	22.8	28.3	28.3	31.3	33.3
D2 H7	20	25	25	28	30
b	73.5		75		
r	45		50		
B	92		111		
G	90		100		
V	97		117		
C2	100		120		
F2	9		9		
N1	4		4		
M1	13.8		13.8		
D1h6	12		12		
d ₁	M4x10		M4x10		
L1	17.5		17.5		
h	113		120.2		
T	195.5		207.7		
	TA... - TF..				
kg	4.5		6.0		

	TA...- TF...				
	56C		63C		
	73.5		75		
	9		9		
	45		50		
	65		70		
	65		80		
	65		70		
	M8 x 12		M8 x 14		
	70		80		
	85		100		
	94		100		
	36		50		
	9		9		
	45		55		
	73.5		80		
	6	8	8	8	8
	22.8	28.3	28.3	31.3	33.3
	20	25	25	28	30
	73.5		75		
	45		50		
	92		111		
	90		100		
	97		117		
	100		120		
	9		9		
	4		4		
	13.8		13.8		
	12		12		
	M4x10		M4x10		
	17.5		17.5		
	146.6		153.7		
	229		241.2		
	TA... - TF..				
	5.0		6.5		

IEC..B5	TF...																			
	56B					56C					63B					63C				
	56	63	71	80	90	56	63	71	80	90	56	63	71	80	90	56	63	71	80	90
Y	120	140	160	200	200	120	140	160	200	200	120	140	160	200	200	120	140	160	200	200
P	153	156	163	183	183	187	190	197	217	217	160	163	170	190	190	194	197	201	221	221
Q	218	221	228	248	248	252	255	262	282	282	230	233	240	260	260	264	267	271	291	291
kg	4.5	4.5	4.5	4.5	4.5	5.0	5.0	5.0	5.0	5.0	6.0	6.0	6.0	6.0	6.0	6.5	6.5	6.5	6.5	6.5

IEC..B14	TF...																			
	56B					56C					63B					63C				
	56	63	71	80	90	56	63	71	80	90	56	63	71	80	90	56	63	71	80	90
Y	—	—	105	120	140	—	—	105	120	140	—	—	105	120	140	—	—	105	120	140
P	—	—	163	183	183	—	—	197	217	217	—	—	170	190	190	—	—	204	224	224
Q	—	—	228	248	248	—	—	262	282	282	—	—	240	260	260	—	—	274	294	294
kg	—	—	4.5	4.5	4.5	—	—	5.0	5.0	5.0	—	—	6.0	6.0	6.0	—	—	6.5	6.5	6.5

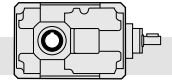

T..56B - T..56C - T..63B - T..63C

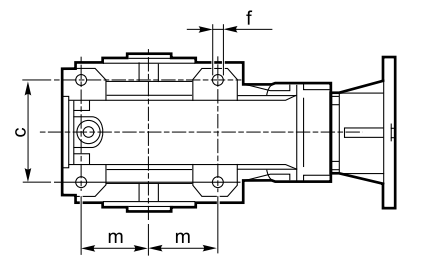
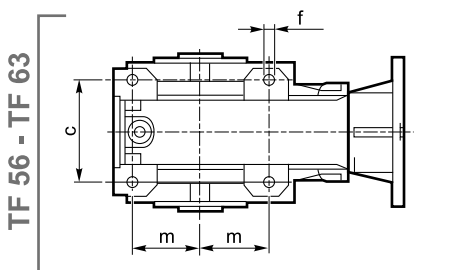
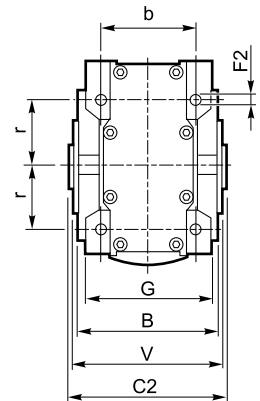
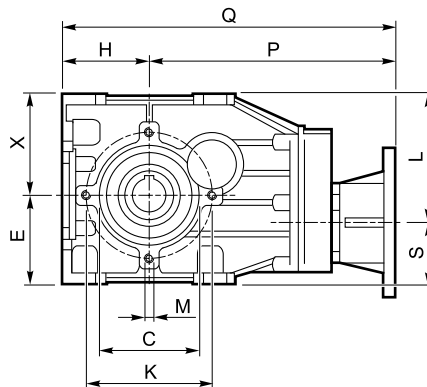
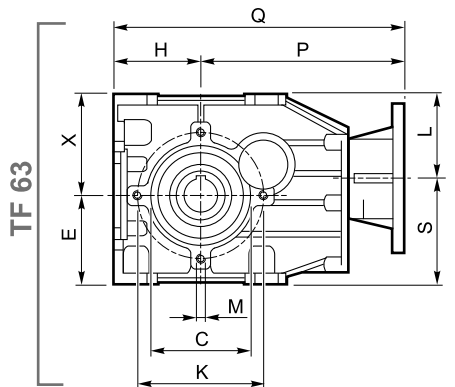
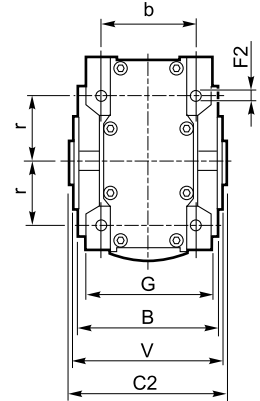
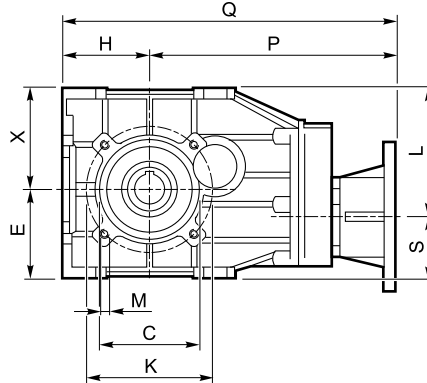
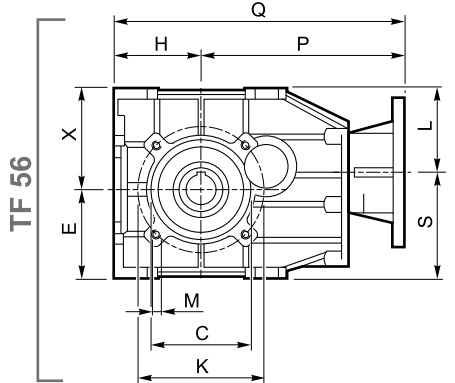
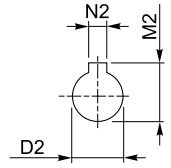
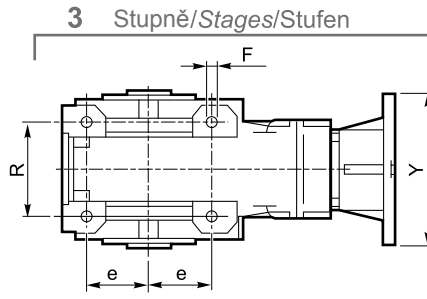
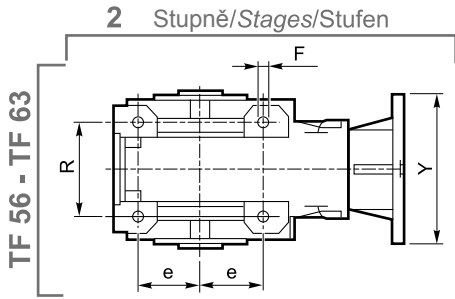

IEC	
	56 B5
	63 B5
	71 B5
	80 B5/B14
	90 B5/B14

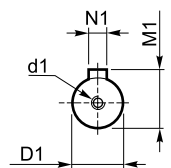
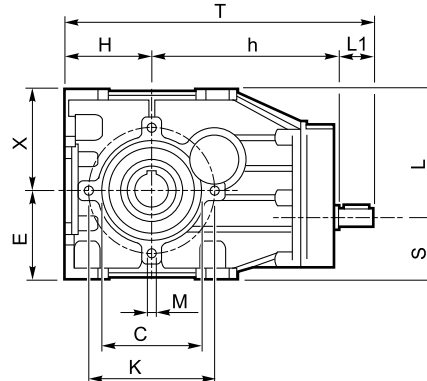
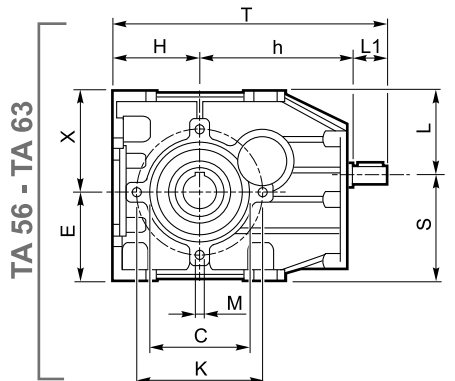

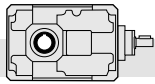

2.10 Rozměry

2.10 Dimensions

2.10 Abmessungen

	TA... - TC... - TF..																
	71B			90B			112B			140B		180B		200B		225B	
A	142			180			224			280		360		400		450	
a	102			134			166			209		272.5		305		344	
a1	—			—			—			—		—		—		—	
B	112			127			150			175		215		255		290	
b	90			104			125			145		180		210		240	
C2	115			130			155			180		220		260		300	
D1 h6	14			19			24			28		38		38		48	
D2 H7	24	28	30	32	30	35	42	40	45	55	50	70	60	90	80	100	90
E	206			262			326			407		522.5		585		654	
e	38			52			64			82		110		120		140	
F	9			11			13			15		17		19		21	
f	M8x13			M10x16			M12x19			M14x22		M16x25		M18x35		M18x30	
G	122			155			194			244		320		350		400	
g	61			77.5			97			122		160		175		200	
H	71			90			112			140		180		200		225	
h	174			212			262			317		400		422.5		500	
I	110			130			160			190		237.5		237.5		296	
i	125			159.5			199			249		322.5		360		404	
L1	30			40			50			60		80		80		110	
O	64			82			102			127		162.5		185		204	
T	275			342			424			517		660		702.5		835	
t	211			260			322			390		497.5		517.5		631	
Z	9			11			13			16		20		22		25	

TA..														
kg	12.5		20		34		58		116		165		232	

TC... - TF...														
kg	15.5		25		44		75		136		185		270	

	TC...												
	71B				90B				112B				
IEC	63 B5	71 B5	80/90 B5	80 B14	71 B5	80/90 B5	*90 B14	100/112 B5	80/90 B5	100/112 B5	132 B5		
Y	140	160	200	120	160	200	□ 120 / R73	250	200	250	300		
P	177	184	204	204	220	240	240	250	286	296	318		
p	113	120	140	140	138	158	158	168	184	194	216		
Q	248	255	275	275	310	330	330	340	398	408	430		
q	184	191	211	211	228	248	248	258	296	306	328		

	140B				180B				200B					
	80/90 B5	100/112 B5	132 B5	160/180 B5	100/112 B5		132 B5	160/180 B5	200 B5	100/112 B5		132 B5	160/180 B5	200 B5
IEC	200	250	300	350	250		300	350	400	250		300	350	400
Y	331	341	363	393	413(i=10-40) / 423(i=50-80)		463(i=10-40) / 473(i=50-80)		400	435(i=8-40) / 445(i=50-63)		485(i=8-40) / 495(i=50-63)		
P	204	214	236	266	250(i=10-40) / 260(i=50-80)		300(i=10-40) / 310(i=50-80)		400	250(i=8-40) / 260(i=50-63)		300(i=8-40) / 310(i=50-63)		
p	204	214	236	266	250(i=10-40) / 260(i=50-80)		300(i=10-40) / 310(i=50-80)		400	250(i=8-40) / 260(i=50-63)		300(i=8-40) / 310(i=50-63)		
Q	471	481	503	533	593(i=10-40) / 603(i=50-80)		643(i=10-40) / 653(i=50-80)		400	640(i=8-40) / 650(i=50-63)		690(i=8-40) / 700(i=50-63)		
q	344	354	376	406	430(i=10-40) / 440(i=50-80)		480(i=10-40) / 490(i=50-80)		400	450(i=8-40) / 460(i=50-63)		500(i=8-40) / 510(i=50-63)		

* Čtvercová příruba / Square flanges / Viereckige Flansche

	TF...												
	71B			90B			112B			140B			
IEC	63 B5	71 B5	80/90 B5	71 B5	80/90 B5	100/112 B5	80/90 B5	100/112 B5	132 B5	80/90 B5	100/112 B5	132 B5	160/180 B5
Y	140	160	200	160	200	250	200	250	300	200	250	300	350
P	231	238	259	286	307	317	367	377	398	432	442	463	493
p	167	174	195	204	225	235	265	275	296	305	315	336	366
Q	302	309	330	376	397	407	479	489	510	572	582	603	633
q	238	245	266	294	315	325	377	387	408	445	455	476	506

	180B				200B				225B				
	100/112 B5	132 B5	160/180 B5	200 B5	100/112 B5	132 B5	160/180 B5	200 B5	225 B5	132 B5	160/180 B5	200 B5	225 B5
IEC	250	300	350	400	250	300	350	400	450	300	350	400	450
Y	546	566	596	596	568.5	588.5	618.5	620.5	648.5	698	728	728	760
P	393.5	403	433	433	383.5	403.5	433.5	435.5	466.5	494	524	524	556
p	736	746	776	776	768.5	788.5	818.5	820.5	848.5	923	953	953	985
Q	736	746	776	776	768.5	788.5	818.5	820.5	848.5	923	953	953	985
q	573.5	583	613	613	583.5	603.5	633.5	635.5	663.5	774	749	749	781

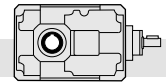

T..71B - T..225B

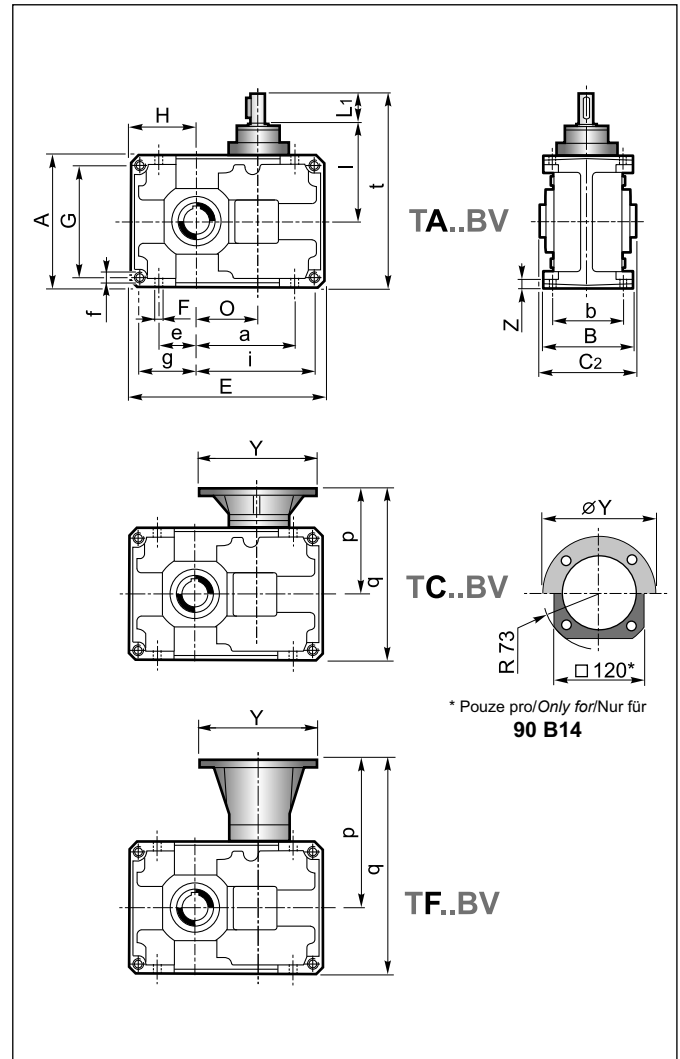
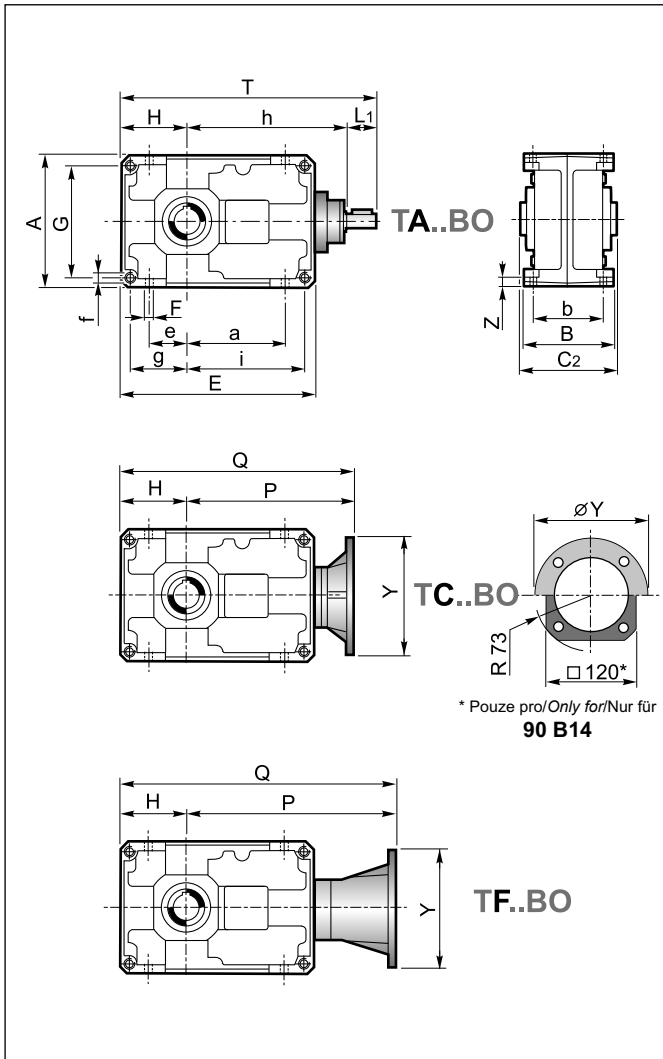

* Pouze pro/Only for/Nur für
90 B14

* Pouze pro/Only for/Nur für
90 B14

Dutá výstupní hřídel
Hollow output shaft
Abtriebshohlwelle

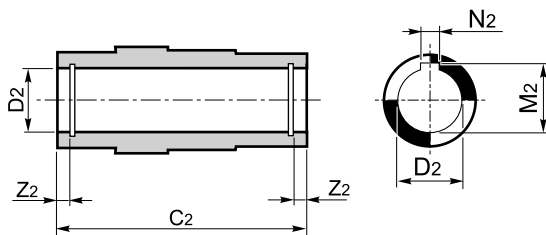

Vstupní hřídel
Input shaft
Antriebswelle

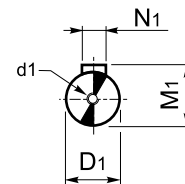

TA... - TC... - TF...

	71B		90B			112B			140B		180B		200B		225B		
D1 h6	14		19			24			28		38		38		48		
d1	M4x15		M8x22			M8x22			M8x22		M10x28		M10x28		M12x34		
M1	16		21.5			27			31		41		41		51.5		
N1	5		6			8			8		10		10		14		
C2	115		130			155			180		220		260		300		
D2 H7	24	28	30	32	30	35	42	40	45	55	50	70	60	90	80	100	90
M2	27.3	31.3	33.3	35.3	33.3	38.3	45.3	43.3	48.8	59.3	53.8	74.9	64.4	95.4	85.4	106.4	95.4
N2	8	8	8	10	8	10	12	12	14	16	14	20	18	25	22	28	25
Z2	—		8.7		8.7	8.4	11	11	11	11.9	11.9	15.4	15.9	18.9	18.9	20	-

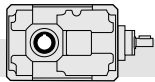

2.10 Rozměry

2.10 Dimensions

2.10 Abmessungen

TA... - TC... - TF...														
	80C			100C			125C		160C		180C		200C	
A	160			200			250		320		360		400	
a	82			102			127		162.5		185		204	
a1	106			134			169		217		207		277.5	
B	127			150			175		215		255		290	
b	104			125			145		180		210		240	
C2	130			155			180		220		260		300	
D1 h6	14			19			24		28		28		38	
D2 H7	32	30	35	42	40	45	55	50	70	60	90	80	100	90
E	306			384			479		609.5		652		766.5	
e	42			52			67		90		100		115	
F	11			13			15		17		19		21	
f	M10x16			M12x19			M14x22		M16x25		M18x35		M18x30	
G	135			170			214		280		310		350	
g	67.5			85			107		140		155		175	
H	80			100			125		160		180		200	
h	256			314			389		479.5		502		604	
I	110			130			160		190		190		237.5	
i	213.5			269			336		429.5		447		541.5	
L1	30			40			50		60		60		80	
O	146			184			229		289.5		312		366.5	
T	366			454			564		699.5		742		884	
t	220			270			335		410		430		517.5	
Z	11			13			16		20		22		25	

TA..									
kg	19		36		66		120	170	260

TC... - TF...									
kg	22		41		76		137	190	295

TC...											
	80C			100C				125C			
IEC	63 B5	71 B5	80/90 B5	80 B14	71 B5	80/90 B5	*90 B14	100/112 B5	80/90 B5	100/112 B5	132 B5
Y	140	160	200	120	160	200	□ 120 / R 73	250	200	250	300
P	259	266	286	286	322	342	342	352	413	423	445
p	113	120	140	140	138	158	158	168	184	194	216
Q	339	346	366	366	422	442	442	452	538	548	570
q	193	200	220	220	238	258	258	268	309	319	341

	160C				180C				200C				
IEC	80/90B5	100/112 B5	132 B5	160/180 B5	80/90 B5	100/112 B5	132 B5	160/180 B5	100/112 B5		132 B5	160/180 B5	200 B5
Y	200	250	300	350	200	250	300	350	250		300	350	400
P	493	503	525	555	516	526	548	578	617(i=40-160) / 627(i=200-315)		667(i=40-160) / 677(i=200-315)		
p	204	214	236	266	204	214	236	266	250(i=40-160) / 260(i=200-315)		300(i=40-160) / 310(i=200-315)		
Q	653	663	686	715	696	706	728	758	617(i=40-160) / 627(i=200-315)		867(i=40-160) / 877(i=200-315)		
q	364	374	396	426	384	394	416	446	450(i=40-160) / 460(i=200-315)		500(i=40-160) / 510(i=200-315)		

* Čtvercová příruba / Square flanges / Viereckige Flansche

TF...										
	80C			100C			125C			
IEC	63 B5	71 B5	80/90 B5	71 B5	80/90 B5	100/112 B5	80/90 B5	100/112 B5	132 B5	
Y	140	160	200	160	200	250	200	250	300	
P	313	320	341	388	409	419	494	504	525	
p	167	174	195	204	225	235	265	275	296	
Q	393	400	421	488	509	519	619	629	650	
q	247	254	275	304	325	335	390	400	421	

	160C				180C				200C			
IEC	80/90 B5	100/112 B5	132 B5	160/180 B5	80/90 B5	100/112 B5	132 B5	160/180 B5	100/112 B5	132 B5	160/180 B5	200 B5
Y	200	250	300	350	200	250	300	350	250	300	350	400
P	594	604	625	655	617	627	648	678	750	770	800	802
p	305	315	336	366	305	315	336	366	383.5	404	434	436
Q	754	764	785	815	797	807	828	858	950	970	1000	1002
q	465	475	496	526	485	495	516	546	583.5	604	634	636

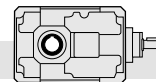

T..80C - T..200C

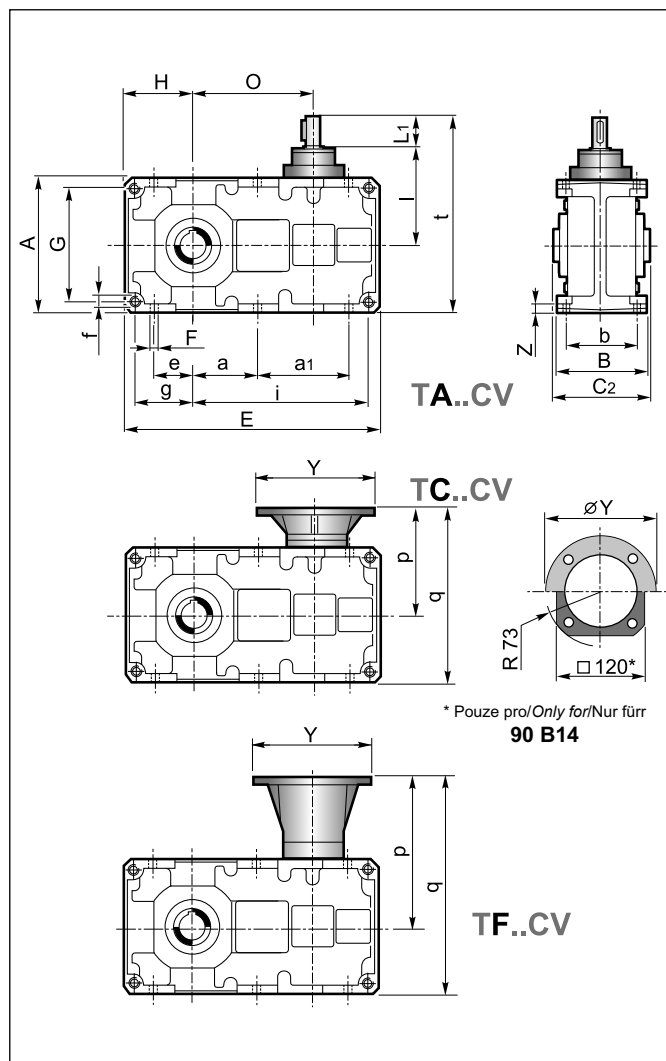
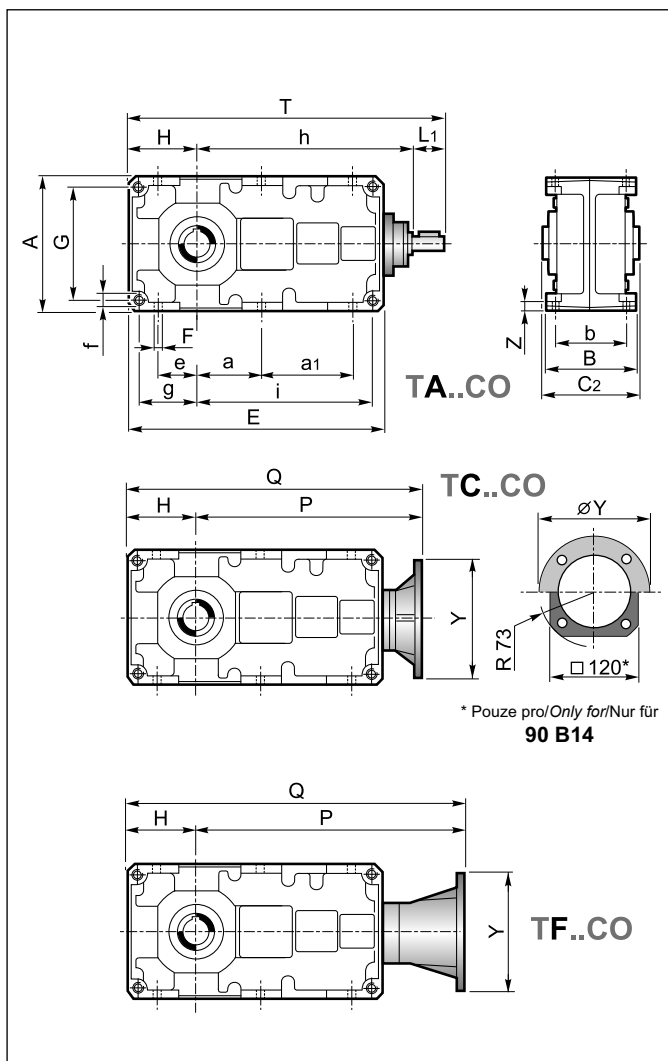

* Pouze pro/Only for/Nur für
90 B14

* Pouze pro/Only for/Nur für
90 B14

Dutá výstupní hřídel
Hollow output shaft
Abtriebshohlwelle

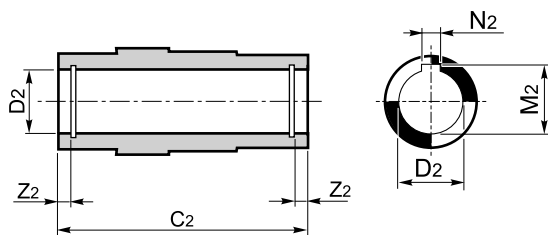

Vstupní hřídel
Input shaft
Antriebswelle

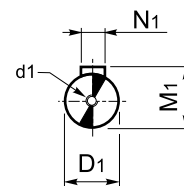

TA... - TC... - TF...

	80C		100C			125C		160C		180C		200C			
D1 h6	14		19			24		28		28		38			
d1	M4x15		M8x22			M8x22		M8x22		M8x22		M10x28			
M1	16		21.5			27		31		31		41			
N1	5		6			8		8		8		10			
C2	130		155			180		220		260		300			
D2 H7	32	30	35	42	40	45	55	50	70	60	90	80	100	90	
M2	35.3	33.3	38.3	45.3	43.3	48.8	59.3	53.8	74.9	64.4	95.4	85.4	106.4	95.4	
N2	10	8	10	12	12	14	16	14	20	18	25	22	28	25	
Z2	8.7		8.7			8.4	11	11	11	15.4	15.9	18.9	18.9	20	-

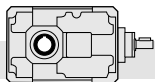

2.11 Příslušenství

2.11 Accessories

2.11 Zubehör

Výstupní hřídel

Output shaft

Abtriebswelle

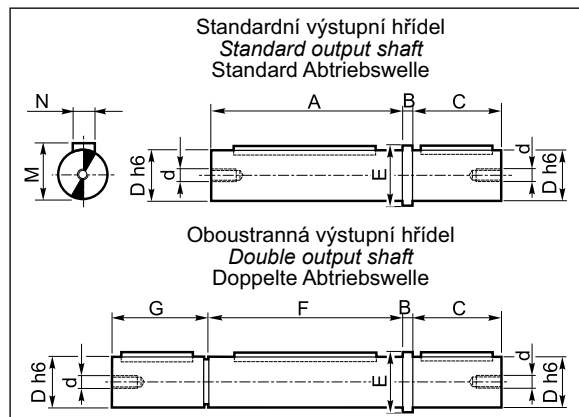

Mat. výstupní hřídele: **C45**
Output shaft material: **C45**
Material der Abtriebswelle: **C45**

	T										
	56B 56C	63B 63C	71B	90B 80C	112B 100C	140B 125C	180B 160C	200B 180C	225B 200C		
A	100	120	114	129	129	154	154	179	219	259	298
B	5	5	5	6	6	8	8	10	12	15	15
C	40	45	50	60	60	80	80	100	125	140	180
D _{h6}	20	25	24	32	35	42	45	55	70	90	100
d	M8	M8	M8	M8	M8	M10	M10	M10	M12	M16	M18
E	26	32	30	40	43	50	53	65	80	110	118
F	100	120	115	130	—	155	—	180	220	260	300
G	41	46	49	59	—	79	—	99	124	141	178
M	22.5	28	27	35	38	45	48.5	59	74.5	94	106
N	6	8	8	10	10	12	14	16	20	25	28

Dutá výstupní hřídel se stahovacím kroužkem

Hollow output shaft with shrink disc

Abtriebshohlwelle mit Schrumpfscheibe

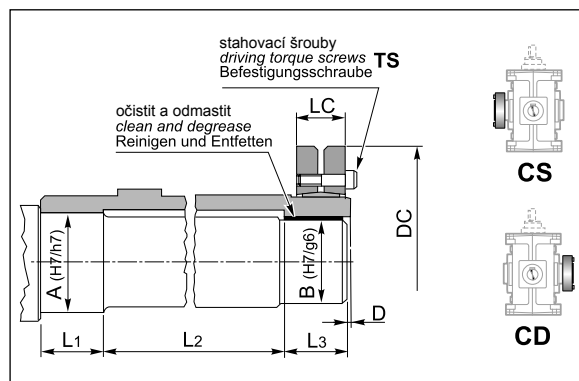

	T									
	56B 56C	63B 63C	71B	90B 80C	112B 100C	140B 125C	180B 160C	200B 180C	225B 200C	
A	27	32	27	37	47	57	72	92	102	
B	25	30	25	35	45	55	70	90	100	
D	2	2	2	2	2	2	2	3	3	
DC	60	72	60	80	100	115	155	188	215	
LC	21.5	23.5	22	26	31	31	39	50	54	
L ₁	32	36	36	39	45	50	60	70	80	
L ₂	61	75	68	82	100	115	143	175	200	
L ₃	32	36	36	39	45	50	60	70	80	
TS _(Nm)	4	12	4	12	12	12	30	59	59	

Ochranný kryt duté výstupní hřídele

Hollow shaft protection kit

Schutzvorrichtung für die Hohlwelle

Na objednání můžeme dodat ochranný kryt duté výstupní hřídele (neplatí pro velikosti 56 a 63). Kryt chrání dutou výstupní hřídel před vniknutím cizích předmětů a kapalin vyskytujících se v pracovním prostředí. Rozměry jsou uvedeny v následující tabulce.

On request we can supply a hollow shaft protection kit (except for sizes 56 and 63). The kit features a gasket which prevents any contact between hollow shaft and foreign bodies or fluids existing in the working environment. Over-all dimensions are reported in the following table.

Auf Wunsch ist eine Schutzvorrichtung für die Hohlwelle lieferbar (Größen 56 und 63 ausgenommen). Die Schutzvorrichtung weist eine Dichtung auf, die zur Vermeidung von irgendwelchem Kontakt zwischen Hohlwelle und Fremdkörper oder Flüssigkeiten der Arbeitsumgebung dient. Den Tabelle wird der Raumbedarf angegeben.

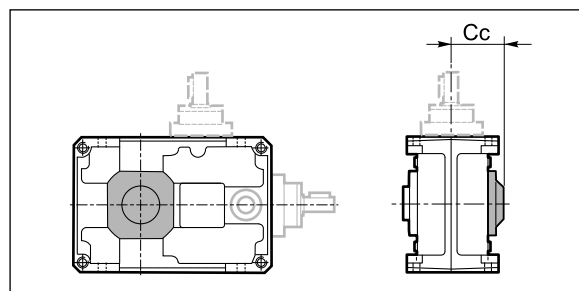

	T						
	71B	90B 80C	112B 100C	140B 125C	180B 160C	200B 180C	225B 200C
Cc	79.5	87	105	120.5	141.5	167.5	191.5

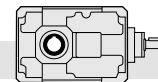

Výstupní příruba

Output flange

Abtriebsflansch

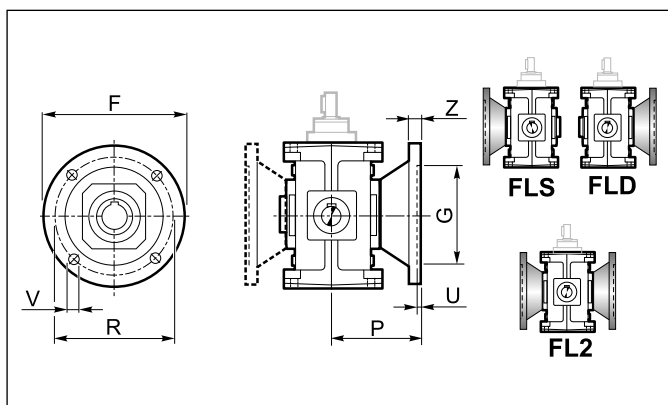

	T							
	56B 56C	63B 63C	71B	90B 80C	112B 100C	140B 125C	180B 160C	200B 180C
F	140	160	160	200	250	300	350	400
G_{G6}	95	110	110	130	180	230	250	300
R	115	130	130	165	215	265	300	350
P	82	91.5	87	100	125	150	180	215
U	5	5	4	4.5	5	5	6	6
V	9	9	12	12	14	16	18	20
Z	15	10	10	12	16	20	25	30
kg	0.5	0.5	2	3.2	5	8	12.5	24

Zkrutová vzpěra

Torque arm

Drehmomentstütze

56B - 56C

63B - 63C

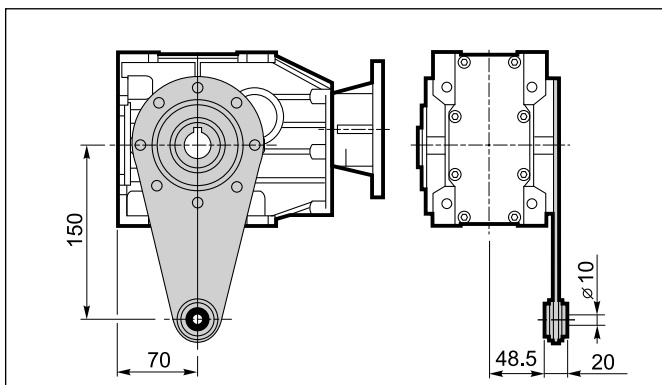
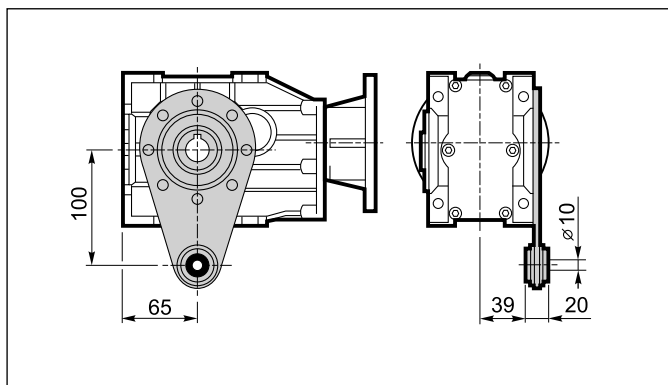

71B - 225B

80C - 200C

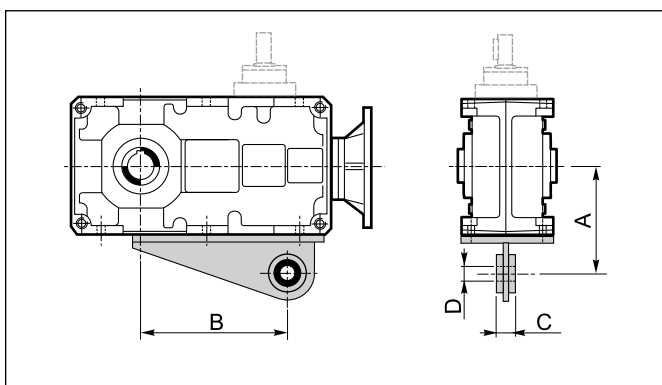
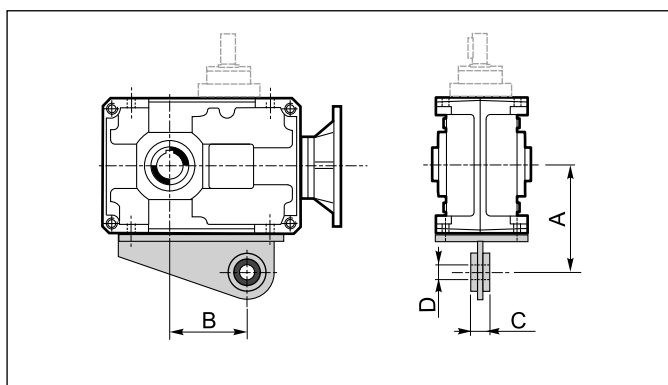

	T						
	71B	90B	112B	140B	180B	200B	225B
A	123	140	172	205	260	300	325
B	84	116	144	189	247.5	280	319
C	25	25	30	30	35	45	45
D	20	20	25	25	35	40	40

	T					
	80C	100C	125C	160C	180C	200C
A	130	160	190	240	280	300
B	170	214	276	354.5	367	456.5
C	25	30	30	35	45	45
D	20	25	25	35	40	40